

HIGH POWER CONNECTORS

MOLDED REMA CONNECTOR MRC 320



Product features and advantages

- Patented high power connector which has been specifically designed for the quick and opportunity charging of large battery capacities
- Compliant with DIN EN 0623-589 and DIN EN 1175
- Various cable sizes from 50 mm² to 107 mm²
- The gas-tight connection between cable and connector housing allows a higher current carrying capacity (Patented MRC technology)
- Used in combination with the REMA Flex cable, which has a special jacket, results in a significantly higher performance and durability.
- Preassembled cables in the different sizes guarantee short installation times and therefore save money.
- High current rated according to DIN VDE 0623-589 (Current Rating II) depending on the cable size
- Special characteristics of the material (chemically coupled, heat and alkali-stabilized copolymer), ensures high resistance against battery acid and UV
- High-grade contacts made out of pure high conductive Cu-ETP copper with silver plated surface and an anti-friction and tarnish coating ensure
 - > a power transition with minimal losses
 - > long life
- Compatible to REMA DIN320
- All accessories of the REMA DIN320 series like pilot contacts, coding pins, airadapter and handles can be interchangeable

1. BASIC STRUCTURE / ORDER NUMBERS

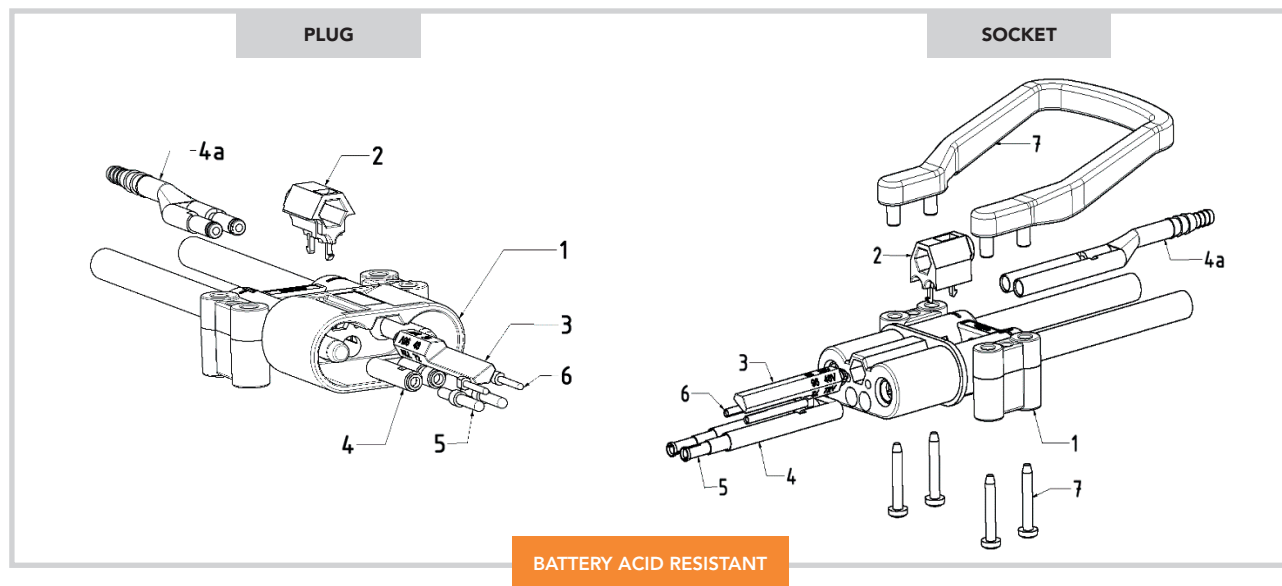

POS.	DESCRIPTION	PART-NR. PLUG	PART-NR. SOCKET
1	MRC 320 - Housing 50 mm ²	on demand	on demand
1	MRC 320 - Housing 70 mm ²	on demand	on demand
1	MRC 320 - Housing 95 mm ²	on demand	on demand
2	Locking part current rating I (320A)	110156	110162
2	Locking part current rating II (400A)	110157	110165
3 ⁽¹⁾	Coding pin grey (wet)	100015	100015
3 ⁽¹⁾	Coding pin green (dry)	100049	100049
3 ⁽¹⁾	Coding pin yellow (wet + dry)	100048	---
3 ⁽²⁾	High power coding pin red (wet)	109631	109632
3 ⁽²⁾	High power coding pin blue (dry)	111375	111376
4	Adapter for pilot contacts	100034	100033
4a	Airadapter	100467	100466
5	Pilot contact 2,5 mm ²	102691	108747
6	Auxiliary contact 1,5 mm ²	120747	120748
7	Handle incl. screws (set)	108880	108880

(1) see page 8

(2) see page 9

2. TECHNICAL SPECIFICATIONS

GENERAL

- > **Nominal voltage U_N** 150 V DC
- > **Current rating I** 320 A acc. DIN VDE 0623-589
- > **Current rating II** 400 A acc. DIN VDE 0623-589
- > **Test voltage** 2 kV AC gem. DIN EN 1175
- > **Temperature range (incl. self-heating)** -20 °C ... +105 °C
-4 °F ... +221 °F
- > **Whole plugging line** app. 45,5 mm
- > **Plugging line main contact** app. 29,0 mm
- > **Plugging line auxiliary contact** app. 8,0 mm

STANDARDS

- > DIN VDE 0623-589
- > DIN EN 1175 (VDE 0117)
- >  File E226710

MATERIAL HOUSING

- | | NORM | >PP-GF30< |
|--|------|-----------|
|--|------|-----------|

MATERIAL CONTACTS

- > Electrolytic high conductive copper Cu-ETP acc. EN 13601 and silver plated surface

CONDUCTOR

- > **Model** Superfine highly flexible Quality - EN 60228/class 6
- > **Conductor Material** Cu-ETP - EN 13602

OUTER INSULATION

- > **Material**
 - > vulcanized thermoplastic elastomer (TPE-V)
 - > black RAL9005 mat
 - > halogen-free
 - > UV- and Ozone resistant
 - > Acid and alkaline resistant
 - > app. 80 Shore A
 - > Flammable resistance V-0 acc. UL-94 / EN 60695-11-10

For more information about REMAFlex® Power cables see REMA technical datasheet PE-TD-001.
Allow us to advise you.

3. HEATING OF MAIN CONTACTS

The REMA® MRC 320 connector system is designed for optimum performance when used 95 mm² cross section cable according DIN VDE 0623-589.

In addition, MRC 320 connectors are able to conduct high current of 400 A according to DIN VDE 0623-589 with a conductor cross section of 95 mm².

At other cable cross section the nominal operation current I_N will different.

The following curves are for reference. The actual thermal performance may vary depending upon environmental conditions.

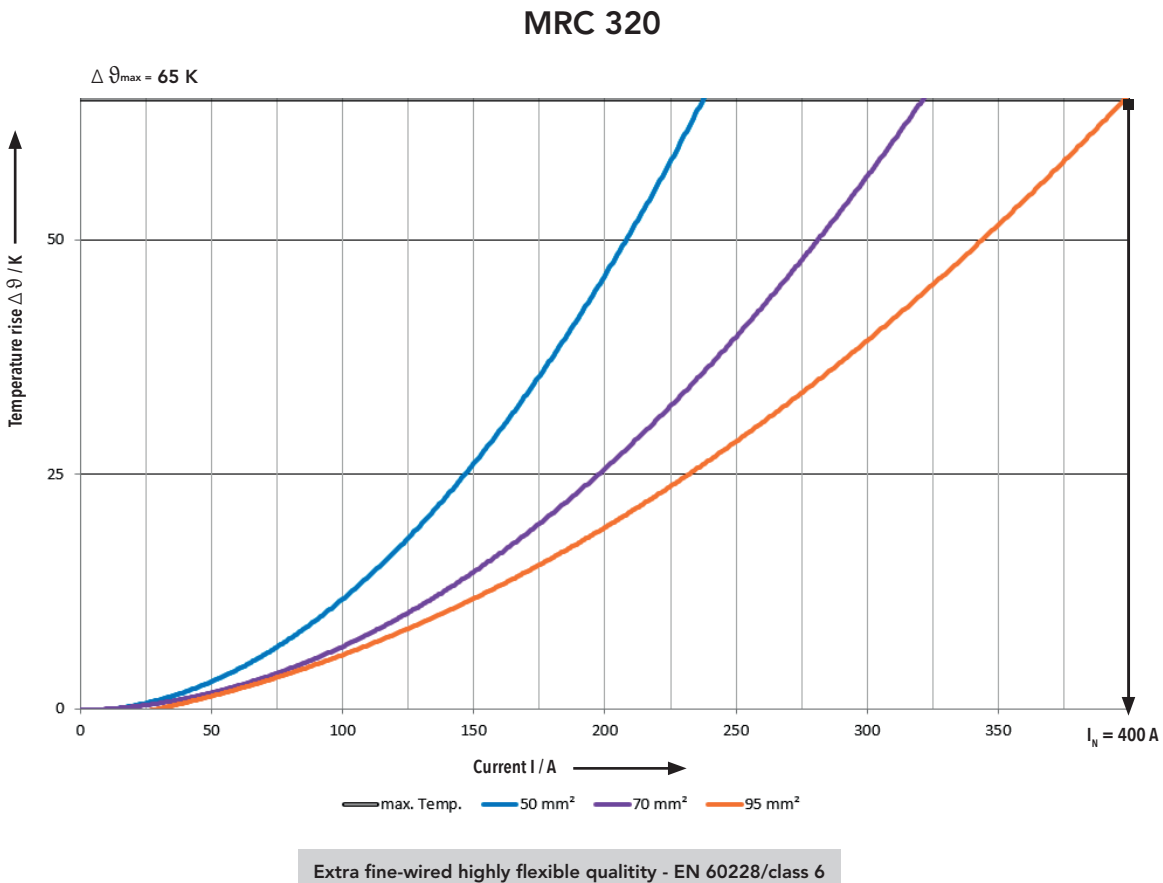

Please contact REMA for additional information concerning of the connector system MRC 320.

4. DRAWINGS

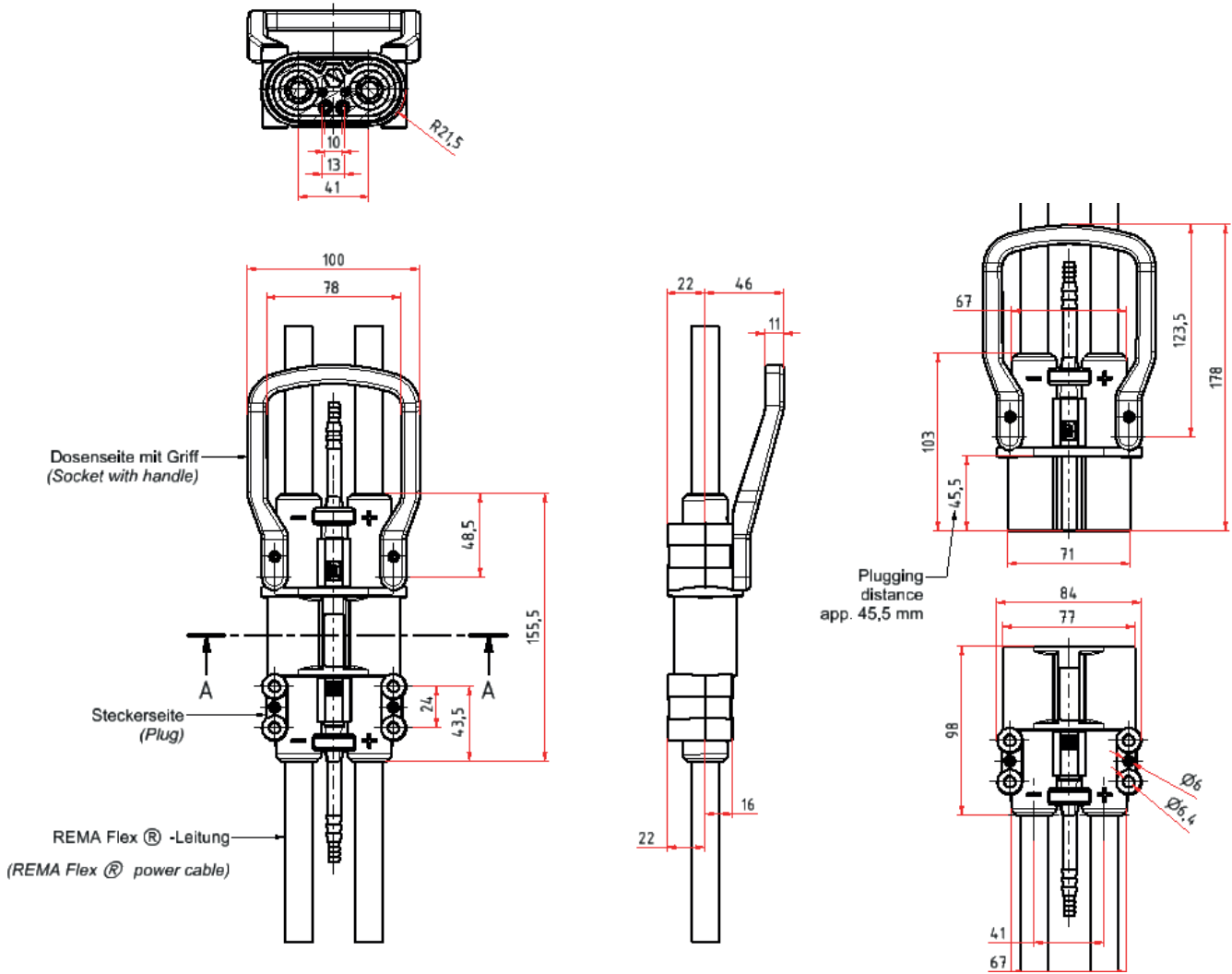

Plugging distance charts REMA® Electrical connector MRC 320

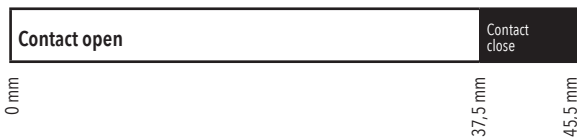

Auxiliary contact

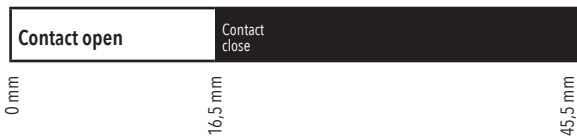

Main contact

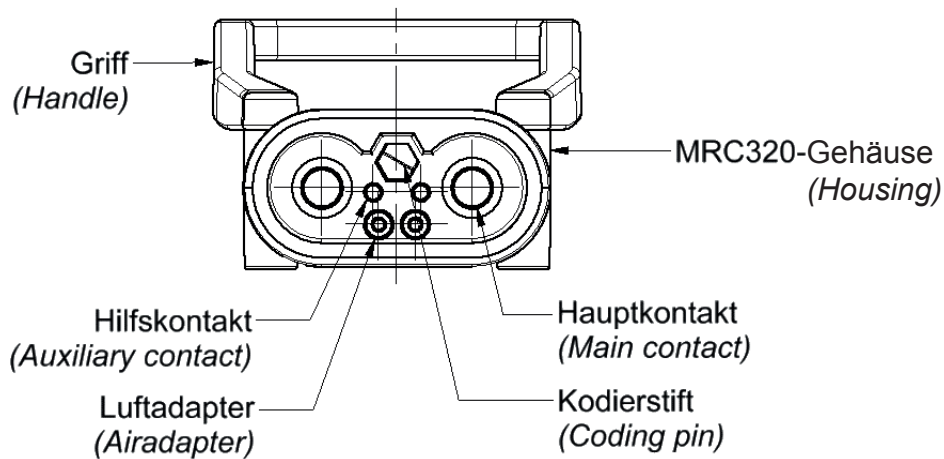

5. CODING

The different types of batteries which are used on the vehicle market today (wet, dry or gel batteries), may only be charged with the right charger for this type of battery.

In extreme cases, unapproved combinations of charge system and batteries can lead to the battery destruction.

In addition, only chargers and batteries with the same voltage may be combined.

The REMA Coding System meets the requirements of DIN VDE 0623-589.

Coding pin for wet batteries

- > **Current rating I:** acc. DIN VDE 0623-589
- > **Color:** grey RAL7035
- > **Voltage range:** 24 V ... 96 V

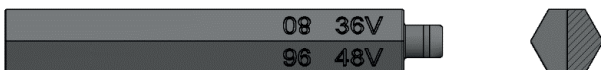

Part-Nr. 100015

Coding pin for dry batteries

- > **Current rating I:** acc. DIN VDE 0623-589
- > **Color:** green RAL6005
- > **Voltage range:** 24 V ... 96 V



Part-Nr. 100049

Universal coding pin (only for plugs) for wet/dry batteries

- > **Current rating I:** acc. DIN VDE 0623-589
- > **Color:** yellow RAL1018
- > **Voltage range:** 24 V ... 96 V



Part-Nr. 100048

High power coding pins

The REMA electrical connector MRC 320 is able to carry the current rating II of 400 A according to DIN VDE 0623-589.

This requires the use of special high-current coding pins and the corresponding locking parts (see page 2).

To prevent connections of a high current rated charger with regular current rated batteries, the red and blue coloured coding pins are additionally equipped with a current coding on the plugs as well as voltage coding.

For the operation of a high-current MRC 400 A-plug device, a cable cross-section 95 mm² in REMAFlex quality is required.

High power coding pins for wet batteries

- > **Current rating II:** 400 A acc. DIN VDE 0623-589
- > **Color:** red RAL3020
- > **Voltage range:** 24 V ... 96 V



Plug: Part-Nr. 109631

Socket: Part-Nr. 109632

High power coding pins for dry batteries

- > **Current rating II:** 400 A acc. DIN VDE 0623-589
- > **Color:** blue RAL5017
- > **Voltage range:** 24 V ... 96 V

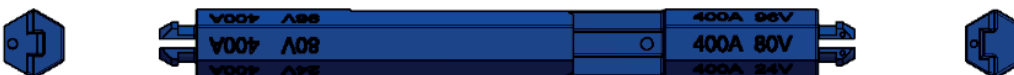

Plug: Part-Nr. 111375

Socket: Part-Nr. 111376