

## REMA BATTERY CONNECTOR DIN80



### Product features and advantages

- > Specifically designed for the quick and opportunity charging of large battery capacities
- > Suitable for lead gel accumulators and lithium-ion batteries
- > Corresponds to the DIN VDE 0632-589 and DIN EN 1175
- > Spring supported contact system for
  - > optimal contact pressure
  - > high electrical conductivity
- > High-grade contacts made out of pure high conductive Cu-ETP copper with silver plated surface and an anti-friction and tarnish coating ensure
  - > power transition with minimal losses
  - > long life
- > Durable because of acid resistant design
- > Suitable for cable sizes from 10 mm<sup>2</sup> to 35 mm<sup>2</sup>
- > Direct crimping without reducing bushing for all cable size
- > Wide range of accessories
  - > different handle shapes
  - > 1 pair of additional auxiliary and 1 pair of pilot contacts
  - > cooling system with air supply through
- > Typical applications
  - > forklift trucks
  - > battery charging systems
  - > sweeper and RCC devices

## 1. STRUCTURE / PART-NUMBERS

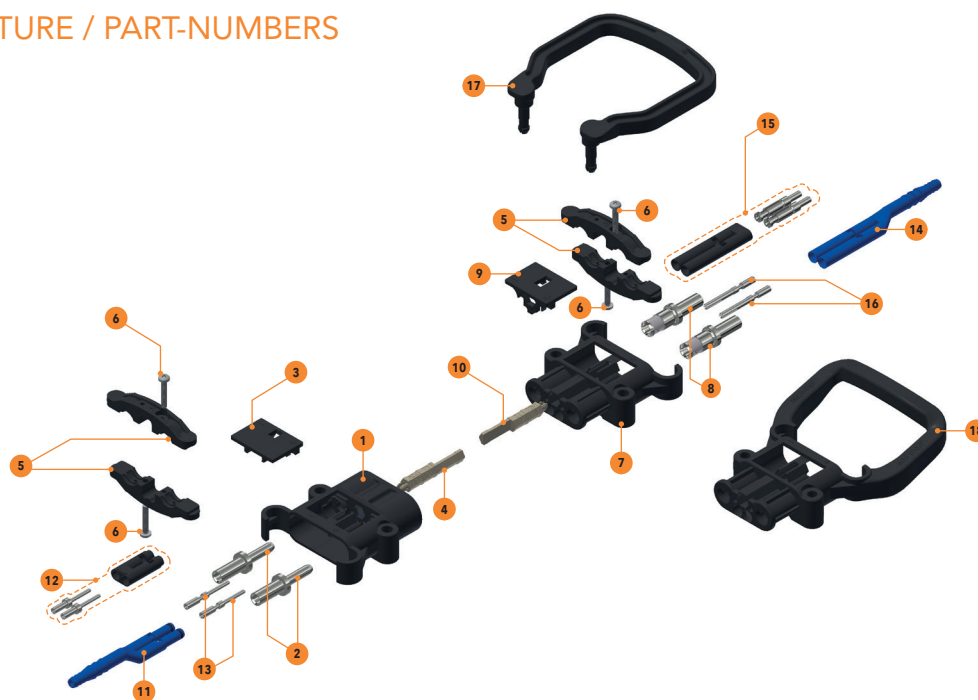

### PLUG AND SOCKET SETS DIN80

DESCRIPTION	SET PARTS	CROSS SECTION	6mm <sup>2</sup>	10mm <sup>2</sup>	16mm <sup>2</sup>	25mm <sup>2</sup>	35mm <sup>2</sup>
DIN80 plug; grey coding; acid resistant	1/2/3/4/5(2x)/6	<b>PART-NO.</b>	108892	111077	108891	108894	108895
DIN80 socket; grey coding; acid resistant	5(2x)/6/7/8/9/10	<b>PART-NO.</b>	---	---	108913	108919	108922
DIN80 socket; grey coding; fixed handle; acid resistant	5(2x)/6/8/9/10/18	<b>PART-NO.</b>	---	---	108914	108935	108920

### ADDITION PARTS DIN80

DESCRIPTION	POSITION	PART-NO.
DIN80 air adapter plug (6 / 8 mm connection)	11	100469
DIN80 pilot cont. set plug	12	108649
DIN80 aux cont. for plug	13	102641
DIN80 air adapter socket (6 / 8 mm connection)	14	100468
DIN80 pilot cont. set socket	15	108657
DIN80 aux cont. for socket	16	102663
DIN80 coding pin grey (wet)	4, 10	100072
DIN80 coding pin yello (wet + dry)	4	100074
DIN80 coding pin grey (dry)	4, 10	100075
DIN80 handle flat incl. Screws M6x30 (set)	17	108905
DIN80 handle flat incl. Screws M6x35 (set)	17	108911
DIN80 handle grey (clip)	17	100441

## 2. TECHNICAL SPECIFICATIONS

### GENERAL

> Nominal voltage $U_N$	150 V DC
> Current rating $I_N^{(1)}$	80 A acc. DIN VDE 0623-589
> Test voltage	2 kVAC acc. DIN EN 1175
> Temperature range (incl. self-heating)	-20 °C ... +105 °C -4 °F ... +221 °F
> Whole plugging line	app. 23 mm
> Plugging line main contact	app. 11,5 mm
> Plugging line auxiliary contact	app. 11,5 mm

(1) depending on the cable crosssection, see page 5

### STANDARDS

- > DIN VDE 0623-589
- > DIN EN 1175 (VDE 0117)
- >  File E226710

### MATERIAL HOUSING

	Standard	>PP-GF30<	>PA-GF30<
> Color		grey sim. RAL7016	black sim. RAL9005
> Halogen-free	DIN VDE 0472-815	yes	yes
> UV resistant		yes	yes
> Ozon resistant		limited	no
> Battery acid resistant	DIN EN 1175	yes	no
> Flammability	UL-94 IEC60695	HB	HB
> Comparative Tracking Index	IEC 60112	600 V	550 V

### MATERIAL CONTACTS

- > Electrolytic high conductive copper Cu-ETP acc. EN 13601 and silver plated surface

### 3. HEATING OF MAIN CONTACTS

The REMA DIN80 connector system is designed for optimum performance when used 16 mm<sup>2</sup> cross section cable according DIN VDE 0623-589.

**At other cable cross section the nominal operation current  $I_N$  will be different.**

The following curves are for reference. The actual thermal performance may vary depending upon environmental conditions.

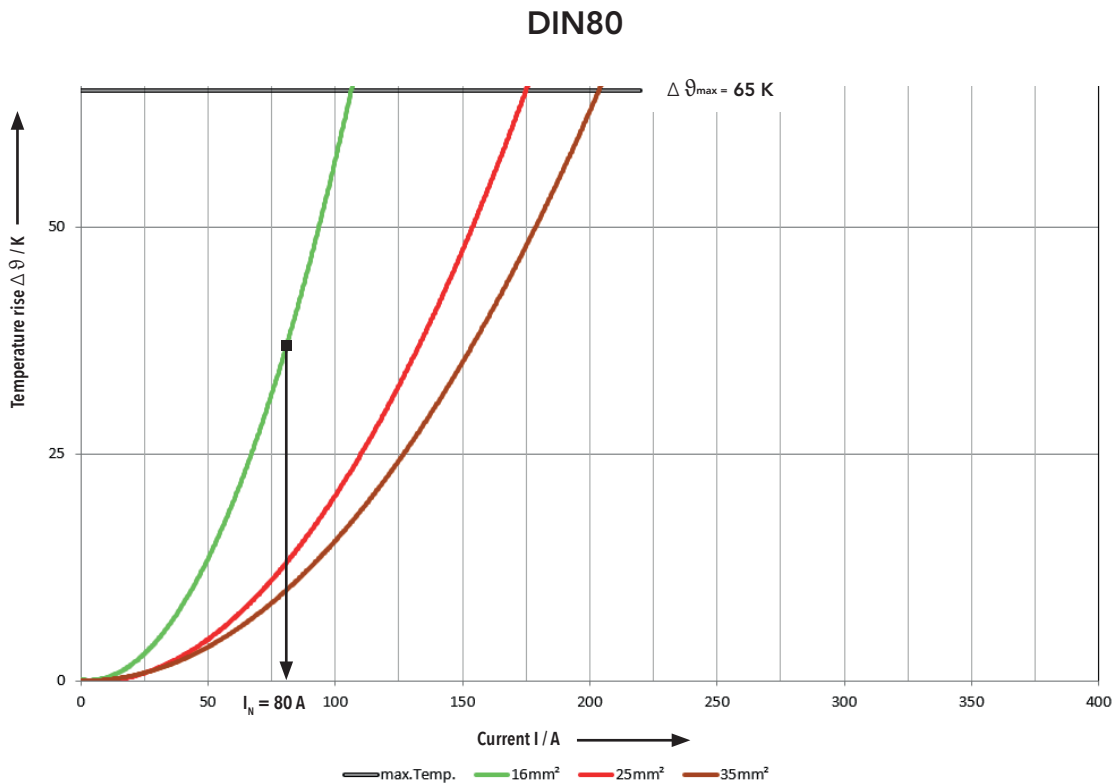

Extra fine-wired highly flexible quality - EN 60228/class 6

Please contact REMA for additional information concerning REMA DIN80 Battery Connector system.

4. DRAWINGS

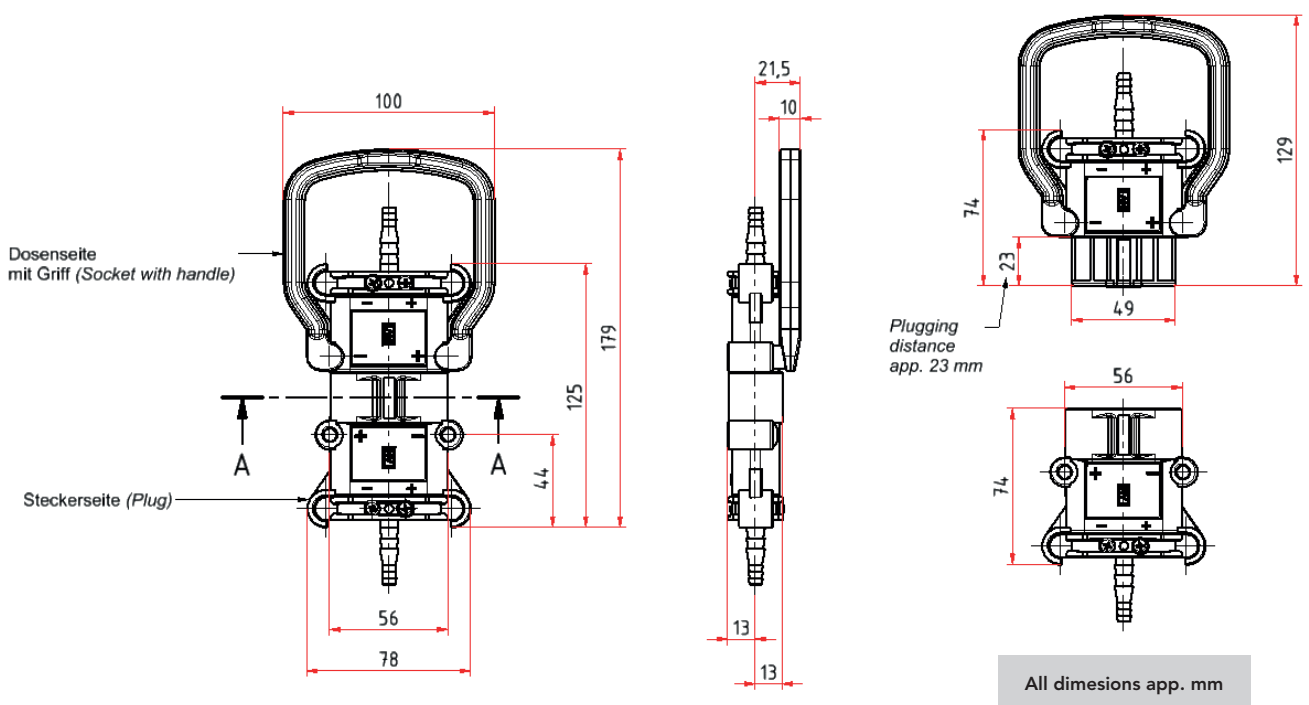

Plugging distance charts REMA Battery Connector DIN80



Preparation wire acc. DIN VDE 0623-589

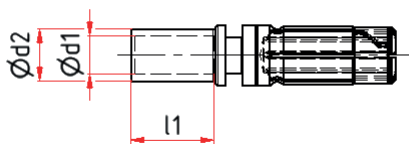

CROSS SECTION [mm <sup>2</sup> ]	Ø d2 [MM] ±0,1	Ø d1 [mm] ±0,1	l1 [mm] ±0,30
6	8,4	3,6	18,0
10	8,4	4,6	18,0
16	8,4	6,1	18,0
25	11,0	8,1	18,0
35	12,5	9,0	18,0

## 5. CODING

The different types of batteries which are used on the vehicle market today (wet, dry or gel batteries), may only be charged with the right charger for this type of battery.

In extreme cases, unapproved combinations of charge system and batteries can lead to the battery destruction.

In addition, only chargers and batteries with the same voltage may be combined.

The REMA Coding System meets the requirements of DIN VDE 0623- 589.

### Coding pin for wet batteries

- > **Current rating I:** acc. DIN VDE 0623-589
- > **Color:** Grey RAL7035
- > **Voltage range:** 24 V ... 96 V

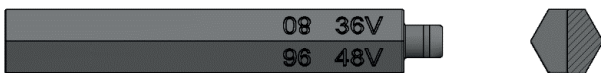

Part-No. 100072

### Coding pin for dry batteries

- > **Current rating I:** acc. DIN VDE 0623-589
- > **Color:** Green RAL6005
- > **Voltage range:** 24 V ... 96 V



Part-No. 100075

### Universal coding pin (only for plugs)

for wet/dry batteries

- > **Current rating I:** acc. DIN VDE 0623-589
- > **Color:** Yellow RAL1018
- > **Voltage range:** 24 V ... 96 V



Part-No. 100074

## 6. DIE SETS

### General processing information

- Please only use suitable REMA die sets. Only those guarantee a secure electrical connection.
- Please actuate die sets always until the end.
- Only process contacts with clean sleeves. The contaminated crimpsleeves increase the contact resistance and may lead to overheating.
- Please always set the die sets centred on the crimp sleeves.

### Hydraulic tool pliers set HP60 Type H60 - Die Sets

- Indent crimping press area 6 – 70 mm<sup>2</sup> Set Part-No. 107138
- Double indent crimping press area 16 – 70 mm<sup>2</sup> Set Part-No. 113032



### Typ C130 - die sets

- Indent crimping press area 10 – 95 mm<sup>2</sup>
- Souple indent crimping press area 10 – 240 mm<sup>2</sup>



For further questions, please contact your REMA Sales department.



### Selection of deliverable range of die sets type C130

CROSS SECTION	TYPE OF DIE SET	PART-NO.
10 mm <sup>2</sup>	indent	104219
16 mm <sup>2</sup>	indent	111092
25 mm <sup>2</sup>	indent	111093
35 mm <sup>2</sup>	indent	111094
50mm <sup>2</sup>	indent	111095
70 mm <sup>2</sup>	indent	111096
95 mm <sup>2</sup>	indent	111097

CROSS SECTION	TYPE OF DIE SET	PART-NO.
10 mm <sup>2</sup>	double indent	107181
16 mm <sup>2</sup>	double indent	107182
25 mm <sup>2</sup>	double indent	107187
35 mm <sup>2</sup>	double indent	107191
50 mm <sup>2</sup>	double indent	107196
70 mm <sup>2</sup>	double indent	107201
95 mm <sup>2</sup>	double indent	107204
120 mm <sup>2</sup>	double indent	107208
240 mm <sup>2</sup>	double indent	107212

### Selection of deliverable range of die sets type H60

CROSS SECTION	TYPE OF DIE SET	PART-NO.
6 mm <sup>2</sup>	indent	110676
10 mm <sup>2</sup>	indent	107264
16 mm <sup>2</sup>	indent	107265
25 mm <sup>2</sup>	indent	107266
35 mm <sup>2</sup>	indent	107267
50 mm <sup>2</sup>	indent	107268
70 mm <sup>2</sup>	indent	112717

CROSS SECTION	TYPE OF DIE SET	PART-NO.
16 mm <sup>2</sup>	double indent	107270
25 mm <sup>2</sup>	double indent	107271
35 mm <sup>2</sup>	double indent	107272
50 mm <sup>2</sup>	double indent	107273
70 mm <sup>2</sup>	double indent	112714
95 mm <sup>2</sup>	double indent	107275

## 7. POWER CABLE

The cables of the REMA DIN High-Power DC Connector System are extra fine-wired flexible copper cables according to EN 60228 / class 6.

CROSS SECTION	CABEL PART-NO.	
10 mm <sup>2</sup>	REMA Flex® V0 119021	H01N2-D 103115
16 mm <sup>2</sup>	REMA Flex® V0 104789	H01N2-D 103116
25 mm <sup>2</sup>	REMA Flex® V0 104751	H01N2-D 103121
35 mm <sup>2</sup>	REMA Flex® V0 104752	H01N2-D 103124
50 mm <sup>2</sup>	REMA Flex® V0 104753	H01N2-D 103128
70 mm <sup>2</sup>	REMA Flex® V0 104754	H01N2-D 103129
95 mm <sup>2</sup>	REMA Flex® V0 104755	H01N2-D 103133
107mm <sup>2</sup>	REMA Flex® V0 119022	
120 mm <sup>2</sup>	REMA Flex® V0 119024	H01N2-D 103136
240 mm <sup>2</sup>		H01N2-D 104354

The REMA Flex® V0 cables listed here comply with DIN EN 1175 and hav an outer insulation made of vulcanized thermoplastic elastomer (TPE-V) and ar flammable resistant class V-0 nach UL-94 / EN 60695-11-10.

For more information about REMA Flex® Power see REMA technical datasheet PE-TD-001.

On request, we are happy to evaluate your special cables and submit an offer for crimp validation.