



## DIRECTIONAL LEDs

Beacons | Lightbars | Minibars | Worklamps | Back-Up Alarms | Camera Systems

## 3730 SERIES SAE Class II Surface Mount

This compact and versatile surface-mount LED directional light is ideal for applications requiring high intensity output, low-current draw and maintenance-free operation. These premium LED heads feature a clear acrylic lens optic with LEDs that illuminate in the color of your choice. Warning capability can be customized by selecting from 14 different flash patterns (via a trigger wire) and synchronizing multiple heads simultaneously or alternately. The coated aluminum base and urethane-sealed electronics protect the unit against the environment, making this one of the most rugged LED products available. And, it's covered by a full 5-year warranty.

### Models

PART NO.	VOLTAGE	AMPS	MOUNT
3730X	12-24	0.3	Surface

Replace X in part number with desired LED color: A = amber, B = blue, C = clear, G = green, R = red

### Features and Benefits

- Rugged die-cast coated aluminum housing with urethane-encapsulated electronics
- 14 flash patterns, including 3 integral alternating flash modes
- Discrete units are colorless when not illuminated
- Multiple units can be synchronized
- LEDs offer a long, maintenance-free service life
- SAE J845 Class II
- CE, R10
- IP Rating 67
- Temperature Range: -22°F to +122°F (-30°C to +50°C)
- Warranty: 5 years

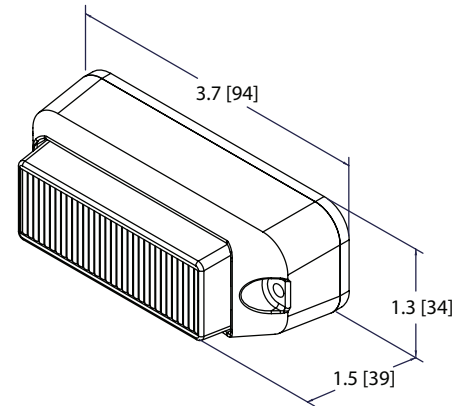

### Flash Patterns (14)

- Steady burn
- Single
- Fast Single
- Double
- Quint
- Pulse8
- Constant Flicker
- Integral Double Alternating

### Accessories

- Universal A3730BKT
- Trunk A3730TNK
- Deck A3730DCK
- Window A3730WIN
- License A3730LIC