

PROPRIETARY RIGHTS ARE CLAIMED FOR THE MATERIAL DISCLOSED IN THIS DRAWING.

LTR.	REVISIONS	DATE
✖	*****	00-00-98

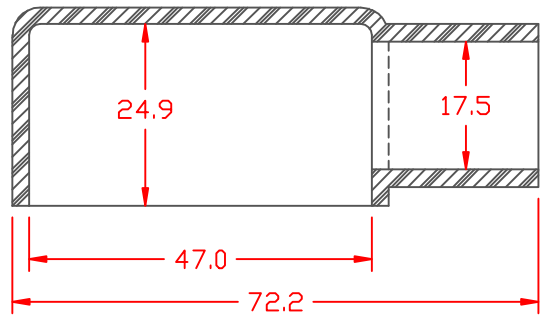
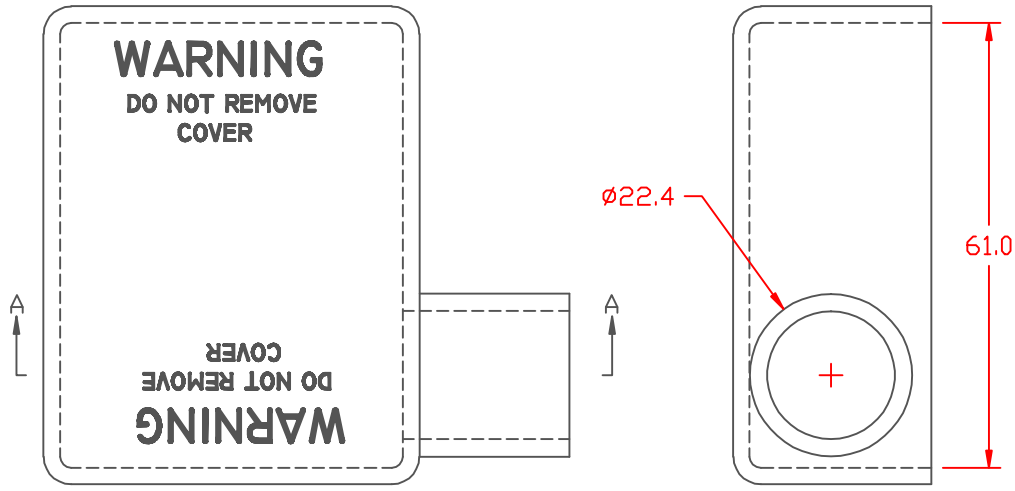

SECTION A-A

VTE Material Part No: 1101650102
 Material: RED PVC
 Material Part No: 9812-65-RED683
 Max. Operating Temp: 105 C
 Shore Durometer "A" 10 SEC. 67/62
 Specific Gravity: 1.34
 Ult. Elongation %: 475
 Brittle Temp: -44 C
 Tensile Strength PSI: 1547 PSI
 Dielectric Strength, v./ml: 540
 U.L. Rating: 94 V2
 MEETS: FMVSS.302

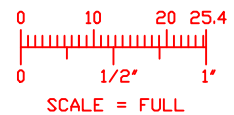

TYP. WALL THICKNESS = 2.3
 TOLERANCE UNLESS OTHERWISE SPECIFIED: ±.030"/±0.8mm
 RADIAL DIAMETERS TO BE MEASURED OVER MANDRELS,
 RING GAGES OR PIN GAGES OF SUITABLE SIZE

		VTE Incorporated 5437 Robinson Road, P.O. Box 790 Pellston, Michigan 49769 Telephone: 1-800-527-9256, 231-539-8000 FAX: 231-539-0914	
		REF:	DATE:
	4-6-98	CHK'D BY:	078 LBS. / 35.5 G.
TITLE: BATTERY CABLE BOOT			
MATERIAL:		PART NO. RIGHT HAND	
		500R9V02	
COLOR:	DRG CLASS		